

**COPPERLINE**<sup>®</sup>

Direct In Line Plug-In  
Surge Protector



The ComNet™ CopperLine® CLESP provides highly effective voltage surge and transient protection for Ethernet-compatible equipment, including Ethernet switches, media converters, EoVDSL modems, ComNet CopperLine Ethernet over UTP transmission extenders, etc. The mating RJ-45 connector on the CLESP plugs directly into any 10/100/1000 BaseT Ethernet port, making the installation simple and quick. Protection is provided to IEC specification EN55024; Immunity Characteristics for Continuous and Transient, Conducted and Radiated Disturbances. Electrostatic discharge (ESD) protection is also provided. For maximum effectiveness, the grounding tab of the CLESP must be securely connected to the frame ground of the installation.

## FEATURES

- › Highly effective voltage surge and transient protection for Ethernet-compatible equipment
- › Small profile: RJ-45 connector-compatible plug-in module saves space in those installations where space may be at a premium
- › Simple and quick installation
- › Economical: Install on those selected Ethernet ports requiring surge and transient protection
- › Provides additional Ethernet port protection for IP cameras, DVRs and NVRs
- › Fully Compatible with any 10/100/1000 BaseT Ethernet port
- › PoE Compatible: IEEE 802.3af and 802.3at compliant for PoE and PoE Plus
- › No additional ground cable required; Grounding tab is integral to the protector

- › Tested and certified to EN61000-4-5 and EN55024 surge standards
- › Designed and manufactured in the U.S.A.
- › Lifetime Warranty

## APPLICATIONS

- › Protection of Ethernet transmission equipment subjected to environments where potentially damaging voltage transients or high levels of electrical noise may be present
- › Long distance UTP cable runs
- › Ethernet Networks in electrically-noisy industrial environments
- › IP cameras and other network equipment operating in environments such as parking lots, warehouses, and perimeter surveillance applications where lightning or other damaging electrical disturbances may exist

SPECIFICATIONS

Electrical

Ethernet Interface	Standard 10/100/1000BaseT
UTP	CopperLine Extended 10/100 Ethernet Cat 5 or higher
Operating Power	No Power Required
Status Indicating LEDs	- Ethernet: Traffic - Link Extended Ethernet Traffic
Connectors	Male RJ-45 Female RJ-45
GND Connection	Via Metal Tab
Standards Compatibility	IEEE 802.3af PoE, IEEE 802.3at PoE

Mechanical

Size (H x W x L)	0.55 x 0.63 x 1.1 in, (14 x 16 x 28 mm)
Weight	0.009 lbs (4 g)

Environmental

Operating Temp	-40°C to +75°C
Storage Temp	-40°C to +85°C
Relative Humidity	0 to 95%, non-condensing

Compliance

Tested and Certified for	IEC 61000-4-2: ESD @ 15Kv (air), 8Kv (contact) EC 61000-4-5: Lighting @ 8/20us IEC 6100-4-2: 2006 EN55024
Compliance Category	B
Let through voltage1	5Kv (air) 8Kv (contact)

ORDERING INFORMATION

Part Number	Description
CLESP	Single Port Ethernet Surge Protector

AGENCY COMPLIANCE

PART 15 COMPLIANT E322911 N24621



DIMENSIONAL DRAWING

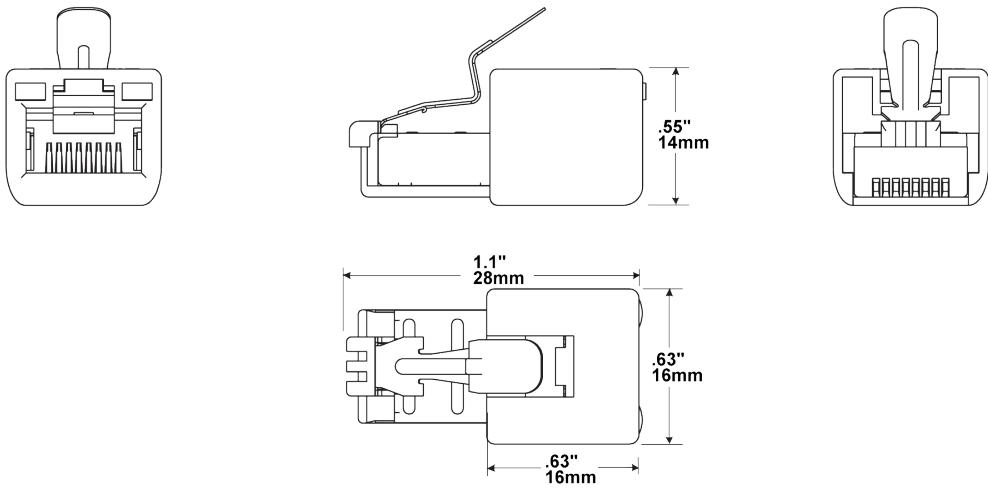

TYPICAL APPLICATION

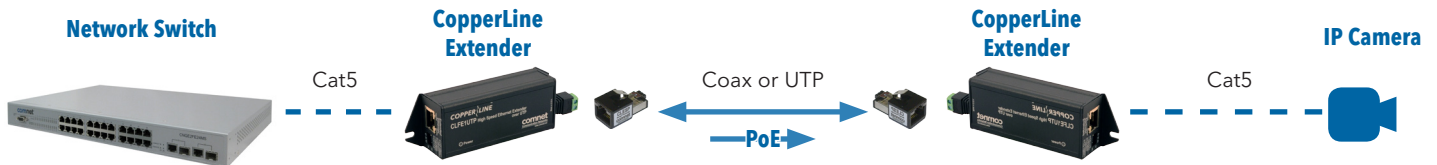

Low Power Consumption